

Defensor®

Defensor Mk5

Änderungen vorbehalten!

Subject to change!

Modifications réservées!

Pos.	Artikel Article Article	Typ Type Type	Visual	Process	Art.-/SAP-Nr. Art.-/SAP-No. Art.-/SAP-No.	
101	Dampfeinsatz kpl. Steam cylinder insert Tête de chauffe cpl.	5 kg	1	1	1115296	
		8 kg	1	1	1115299	
		10 kg	1	1	1115300	
		16 kg	1	1	1115301	
		20 kg	1	1	1115302	
		24 kg	1	1	1115303	
		30 kg	1	1	1115304	
40 kg	1	1	1115305			
102	Dampfzylinder Steam cylinder Cuve à vapeur	5/8/10/16 kg / 200	1	1	1115461	
		20/24/30/40 kg/h / 280	1	1	1115462	
103	Dampfzylinderdeckel Steam cylinder cover Couvercle de cuve	5/8/10 kg/h / 200	1	1	1115464	
		16 kg/h / 200	1	1	1115465	
		20 kg/h / 280	1	1	1115466	
		24/30/40 kg/h / 280	1	1	1115467	
104	Deckelspanning Cover clamping Fermeture du couvercle	5/8/10/16 kg/h / 200	1	1	1103812	
		20/24/30/40 kg/h / 280	1	1	1103814	
105	Durodichtung Gasket Duro Joint Duro	5/8/10/16 kg/h / 200	1	1	1101516	
		20/24/30/40 kg/h / 280	1	1	1100966	
106	Spannverschluss Clamping ring Collier de fermeture	5/8/10/16 kg/h / 200	1	1	1104574	
		20/24/30/40 kg/h / 280	1	1	1104578	
107	Ausblasstutzen kpl. Steam outlet hose cpl. Manchon de vaporisation cpl.	5...40 kg/h	1	1	1103817	
108	Heizstab Heating element Element de chauffage	5 kg / 1250 W	1	1	1115476	
		8/16/24 kg / 2000 W	1	1	1115478	
		10/20/30 kg / 2500 W	1	1	1115480	
		40 kg / 3300 W	1	1	1115482	
		Heizstab (Set à 3 Stk.) Heating element (Set with 3 pcs.) Element de chauffage (Set à 3 pcs.)	5 kg / 1250 W	1	1	1115475
		8/16/24 kg / 2000 W	1	1	1115477	
		10/20/30 kg / 2500 W	1	1	1115479	
40 kg / 3300 W	1	1	1115481			
109	Heizstabdichtungsset (Set à 9 Stk.) Gasket set for heating element (Set with 9 pcs.) Joints pour élément de chauffage (Set à 9 pcs.)	5...40 kg/h	1	1	1113610	
110	Übertemperaturschalter kpl. Thermostat cpl. Thermostat cpl.	5...40 kg/h	1	1	1103822	
111	Kabel zu Übertemperaturschalter kpl. Thermostat cable cpl. Câble pour thermostat cpl.	5...40 kg/h	1	1	1115483	
112	Stecker Connetcor Faisceau Faisceau	5/8/10 kg/h / 10 pol.	1	1	1103825	
		16/20 kg/h / 16 pol.	1	1	1103829	
		24/30 kg/h / 24 pol.	1	1	1103832	
		40 kg/h / 24 pol.	1	1	1119457	
113	Kabelbaum 230-240V/1~ Cable harness 230-240V/1~ Faisceau de câbles 230-240V/1~ Kabelbaum 200-220V/3~ Cable harness 200-220V/3~ Faisceau de câbles 200-220V/3~	5/8/10 kg/h / 10 pol.	1	1	1119718	
		5/8/10 kg/h / 10 pol.	1	1	1119718	
		16/20 kg/h / 16 pol.	1	1	1119719	
		24/30 kg/h / 24 pol.	1	1	1119720	
		40 kg/h / 24 pol.	1	1	1119721	

Pos.	Artikel Article Article	Type Type Type	Visual	Process	Art.-/SAP-Nr. Art.-/SAP-No. Art.-/SAP-No.
113	Kabelbaum 400-415V/3~ Cable harness 400-415V/3~ Faisceau de câbles 400-415V/3~	5/8/10 kg/h / 10 pol.	1	1	1115484
		16/20 kg/h / 16 pol.	1		1115485
		16/20 kg/h / 16 pol.		1	1115486
		24/30 kg/h / 24 pol.	1		1115487
		24/30 kg/h / 24 pol.		1	1115488
		40 kg/h / 24 pol.	1		1119458
		40 kg/h / 24 pol.		1	1119459
114	Zylindereinsatz kpl. Cylinder insert cpl. Insert du cuve cpl.	5/8/10/16 kg/h / 200	1	1	1115489
		20/24/30/40 kg/h / 280	1	1	1115490
115	Einsatzgitter Screen insert Insert grille	5/8/10/16 kg/h / 200	1	1	1115491
		20/24/30/40 kg/h / 280	1	1	1115492
116	Trichterschikane Funnel baffle ring Chicane de l'entonnoir	5...40 kg/h	1	1	1116884
117	Kupplungsmuffe kpl. Coupling sleeve cpl. Manchon d'accouplement cpl.	5...40 kg/h / Standard	1	1	1115494
		5/8/10/16 kg/h / VE 200	1	1	1115495
		20/24/30/40 kg/h / VE 280	1	1	1115496
118	Schnapping gross (inkl. Dichtung) Snap ring large (incl. gasket) Anneau d'arrêt grand (incl. joint)	5...40 kg/h	1	1	1115497
119	Schnapping klein (inkl. Dichtung) Snap ring small (incl. gasket) Anneau d'arrêt petit (incl. joint)	5...40 kg/h	1	1	1115498
120	Kalkauffangbehälter Lime collector tank Collecteur de calcaire	5/8/10/16 kg/h / 500	1	1	1115499
		20/24/30/40 kg/h / 600	1	1	1115500
121	Ablasshahn (inkl. Dichtung) Drain valve (incl. gasket) Robinet de vidange (incl. joint)	5...40 kg/h	1	1	1116889
122	Verschluss Kalkauffangbehälter links+rechts kpl. Rotation locks lime collector tank left+right cpl. Verrouillage de collecteur de calcaire gauche+droit cpl.	5...40 kg/h	1	1	1115502
201	Synchronpumpe kpl. Synchronous pump cpl. Pompe synchrone cpl.	5...40 kg/h	1	1	1115532
202	Dichtring Pumpengehäuse Gasket for pump housing Joint pour boîtier de pompe	5...40 kg/h	1	1	1115533
203	Ablaufbecher kpl. Drain cup cpl. Godet d'écoulement cpl.	5...40 kg/h	1	1	1115534
204	PEX-Schlauchgarnitur PEX hose Tuyau PEX	5...40 kg/h	1	1	1103857
205	Einlassventil kpl. Solenoid inlet valve assy. Vanne d'alimentation cpl.	5/8/10/16 kg/h / 1.2 l	1		1115535
		20/24/30/40 kg/h / 2.0 l	1		1104535
206	Doppel-Einlassventil kpl. Double solenoid inlet valve assy. Double-vanne d'alimentation cpl.	5...20 kg/h / 2/0.8 l		1	1115680
		24...40 kg/h / 2/1.2 l		1	1115536
207	Niveauprint kpl. Print for level control assy. Circuit imprimé pour contrôle de niveau cpl.	5...40 kg/h	1		1115537
		5...40 kg/h		1	1115538
208	Schwimmer kpl. Float assy. Flotteur cpl.	5...40 kg/h	1		1115539
		5...40 kg/h		1	1115540
209	Schwimmerhalter Float holder Support de flotteur	5...40 kg/h	1	1	1115541
210	Wasserbecher kpl. Water cup cpl. Godet d'eau cpl.	5...40 kg/h	1	1	1115542

Pos.	Artikel Article Article	Typ Type Type	Visual	Process	Art.-/SAP-Nr. Art.-/SAP-No. Art.-/SAP-No.
211	Schlauchset Visual Hose set Visual Set de tuyau Visual	5...40 kg/h	1		1115543
212	Schlauchset Process Hose set Process Set de tuyau Process	5...40 kg/h		1	1115544
213	Pumpen-Schlauchset Hose set for drain pump Set de tuyau pour pompe	5...40 kg/h	1	1	1115545
214	Schlauchset Niveaueinheit Hose set for level control unit Set de tuyau pour unité de niveau	5...40 kg/h	1	1	1115546
215	Ablaufstutzen cpl. Drain connection assy. Manchon d'écoulement cpl.	5...40 kg/h	1	1	1103890
216	Klammerset Set clamps Set de colliers	5...40 kg/h	1	1	1116550
217	Schlauchklemmenset Hose clip set Set serre-joint de tuyau	5...40 kg/h	1	1	1115548
301	Dampfanschluss kpl. Steam hose nipple assy. Raccordement vapeur cpl.	5...40 kg/h	1	1	1115503
302	Schloss kpl. (Set mit 2 Stk.) Lock assy. (set with 2 pcs.) Serrure cpl. (set avec 2. pcs.)	5...40 kg/h	1	1	1103860
303	Schalterset (1 Stk. von jedem Schalter) Switch set (1 pc. of each switch) Set interrupteurs (1 pc. de chaque interrupteur)	5...40 kg/h	1	1	1115504
304	Sicherungsset Fuses set Set fusibles	(1x6.3AT/1AF/50mAF, 2x16ASF) 1 (1x6.3AT/1AF/50mAF, 2x20ASF) 2	1 1	1 1	1115505 1115506
305a	Hauptschütz 230-240 V 1~ Main Contactor 230-240 V 1~ Contacteur Principal 230-240 V 1~	5 kg/h 8/10 kg/h	1 1	1 1	1115507 1115511
	Hauptschütz 200-220 V 3~ Main Contactor 200-220 V 3~ Contacteur Principal 200-220 V 3~	5/8/10 kg/h 16/20 kg/h 24/30kg/h 40 kg/h 50 kg/h	1 1 1 1 1	1 1 1 1 1	1115507 1115511 1117502 1117504 1115511
		60 kg/h 80 kg/h	2 2	2 2	1117502 1117504
	Hauptschütz 400-415V 3~ Main Contactor 400-415V 3~ Contacteur Principal 400-415V 3~	5/8/10 kg/h 16/20 kg/h 24/30 kg/h 40 kg/h 50 kg/h	1 1 1 1 1	1 1 1 1 1	1115507 1115509 1115511 1117502 1115509
		60 kg/h 80 kg/h	2 2	2 2	1115511 1117502
305b	Heizungsschütz (nur Visual 400-415 V 3~) Heating Contactor (Visual 400-415 V 3~ only) Contacteur (uniquement Visual 400-415 V 3~)	16/20 kg/h 24/30 kg/h 40 kg/h 50 kg/h 60 kg/h 80 kg/h	1 2 2 3 4 4		1115509 1115509 1115511 1115509 1115509 1115511
306	Folientastatur Keypad Clavier	5...40 kg/h 5...40 kg/h	1		1115513 1115514
307	LC-Display kpl. LC-display assy. Affichage (LCD) cpl.	5...40 kg/h	1	1	1115515

Pos.	Artikel Article Article	Typ Type Type	Visual	Process	Art.-/SAP-Nr. Art.-/SAP-No. Art.-/SAP-No.
308	Steuerkarte 230-240 V 1~	5/8/10 kg/h	1		1115516
	Control board 230-240 V 1~	5/8/10 kg/h		1	1115517
	Platine de commande 230-240 V 1~				
	Steuerkarte 200-220 V 3~	5...40 kg/h	1		1115516
	Control board 200-220 V 3~	5...40 kg/h		1	1115517
	Platine de commande 200-220 V 3~	50...80 kg/h	1		1115518
		50...80 kg/h		1	1115519
	Steuerkarte 400-415 V 3~	5...40 kg/h	1		1115516
	Control board 400-415 V 3~	5...40 kg/h		1	1115517
	Platine de commande 400-415 V 3~	50...80 kg/h	1		1115518
		50...80 kg/h		1	1115519
	309	Speisungsmodul 230-240 V 1~	5...10 kg/h	1	1
Supply module 230-240 V 1~					
Module d'alimentation 230-240 V 1~					
Speisungsmodul 200-220 V 3~		5...80 kg/h	1	1	1115524
Supply module 200-220 V 3~					
Module d'alimentation 200-220 V 3~					
310	Speisungsmodul 400-415 V 3~	5...10 kg/h	1		1115524
	Supply module 400-415 V 3~	16...80 kg/h	1		1115525
	Module d'alimentation 400-415 V 3~	5...80 kg/h		1	1115524
	Leistungssprint 230-240 V 1~	5/8 kg/h	1	1	1116871
	Power board 230-240 V 1~	10 kg/h	1	1	1116872
	Platine de puissance 230-240 V 1~				
	Leistungssprint 200-220 V 3~	5 kg/h	1	1	1116873
	Power board 200-220 V 3~	8 kg/h	1	1	1116874
	Platine de puissance 200-220 V 3~	10 kg/h	1	1	1116875
		16 kg/h	1	1	1116876
		20 kg/h	1	1	1116877
		24 kg/h	1	1	1116879
		30 kg/h	1	1	1116879
		40 kg/h	1	1	1116880
		50 kg/h	1	1	1116877
			1	1	1116879
		60 kg/h	2	2	1116879
		80 kg/h	2	2	1116880
311	Leistungssprint 400-415 V 3~	5/8 kg/h	1	1	1115526
	Power board 400-415 V 3~	10 kg/h		1	1115527
	Platine de puissance 400-415 V 3~	10...30 kg/h	1		1115527
		16/20 kg/h		1	1115528
		24 kg/h		1	1115529
		30 kg/h		1	1115521
		40 kg/h	1		1115520
		40 kg/h		1	1115522
		50 kg/h	2		1115527
		50 kg/h		1	1115521
				1	1115528
		60 kg/h	2		1115527
		60 kg/h		2	1115521
		80 kg/h	2		1115520
		80 kg/h		2	1115522
311	Set BUS-Kabel	5...40 kg/h	1	1	1115530
	Set BUS cable				
	Set câble BUS				
312	Betriebs- und Störungsfernmeldung	5...40 kg/h	1	1	1115360
	Remote operation and fault indication				
	Télésignalisation de travail et de dérangement				
320 *	Türe Wasserseite	5/8/10/16 kg/h	1	1	1115288
	Door water side	5/8/10/16 kg/h / INOX	1	1	1115289
	Porte côté eau	20/24/30/40 kg/h	1	1	1114294
		20/24/30/40 kg/h / INOX	1	1	1115287
321 *	Türe Elektronikseite	5/8/10/16 kg/h	1	1	1115284
	Door electronic side	5/8/10/16 kg/h / INOX	1	1	1115283
	Porte côté électronique	20/24/30/40 kg/h	1	1	1114295
		20/24/30/40 kg/h / INOX	1	1	1115282
	Türe Elektronikseite ohne Displayausschnitt	20/24/30/40 kg/h	1	1	1115286
	Door electronic side without display cutout	20/24/30/40 kg/h / INOX	1	1	1115285
	Porte côté électronique sans découpe affichage				

* **Lieferfrist ca. 6 Wochen / delivery time approx. 6 weeks / délai de livraison approx. 6 semaines**

Pos.	Artikel Article Article	Typ Type Type	Visual	Process	Art.-/SAP-Nr. Art.-/SAP-No. Art.-/SAP-No.
322	Frontpanel Front panel Tableau frontal	5...40 kg/h	1	1	1116577
323 *	Schutzbügel (1 Stk.) Protection bow (1 pc.) Coude de protection (1 pc.)	5/8/10/16 kg/h / 500 5/8/10/16 kg/h / 500 INOX 20/24/30/40 kg/h / 600 20/24/30/40 kg/h / 600 INOX	1 1 1 1	1 1 1 1	1114885 1115280 1114886 1115281
324 *	Linker und rechter Haltebügel zu Kalkauffangbehälter Lime collector tank (left/right) holding devices Dispositif de fixation (gauche/droite) pour collecteur de calcaire	5/8/10/16 kg/h / 500 20/24/30/40 kg/h / 600	1 1	1 1	1115682 1115681
325	Frontpanel mit Folientastatur Front panel with keypad Tableau frontal avec clavier	5...40 kg/h 5...40 kg/h	1	1	1116582 1116581
—	Verbindungskabelset Connection cable set Set câble de connection	5...80 kg/h	1	1	1116883
—	Querstromlüfter Ventilator Ventilateur	40/80 kg/h		1	1115531

* *Lieferfrist ca. 6 Wochen / delivery time approx. 6 weeks / délai de livraison approx. 6 semaines*

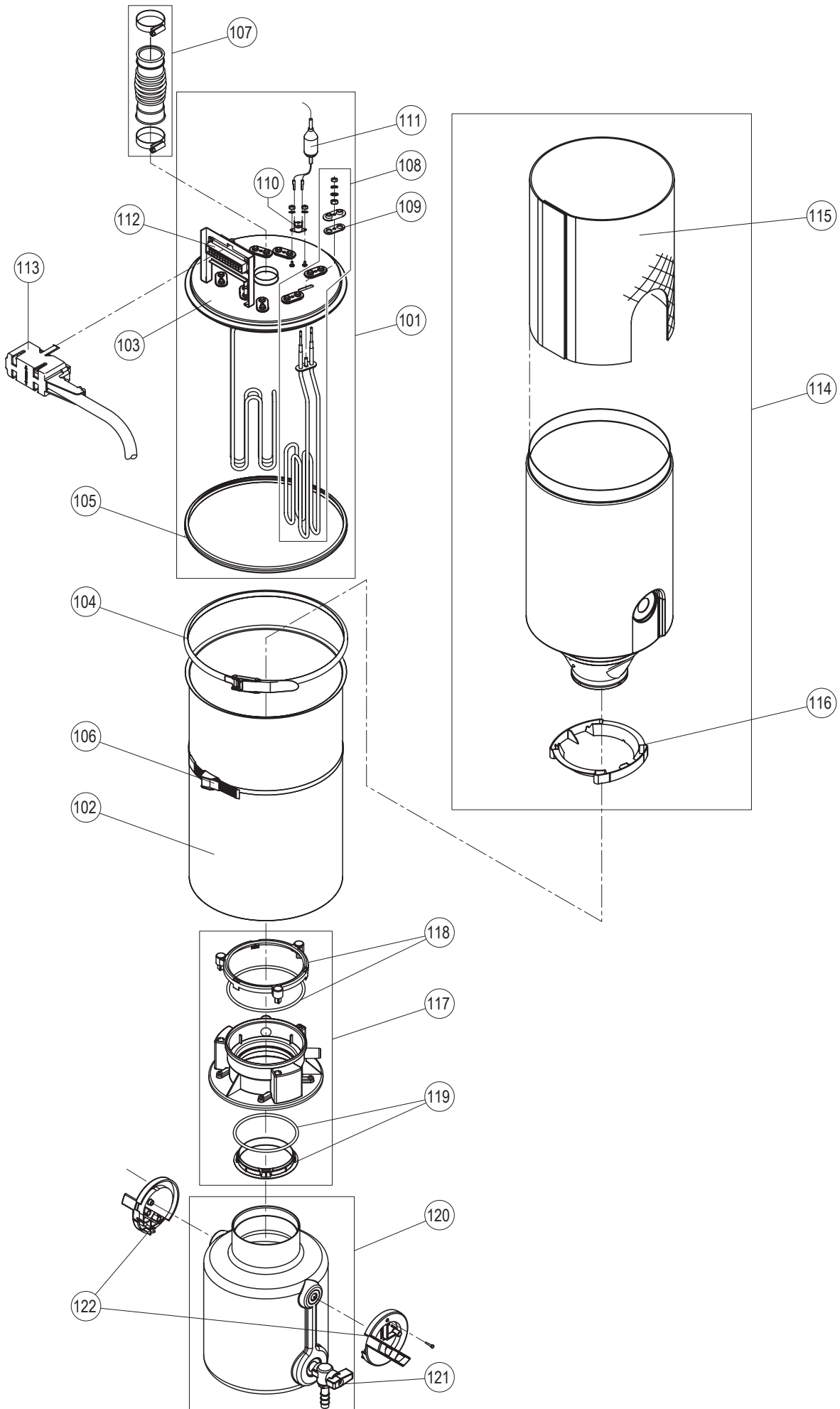

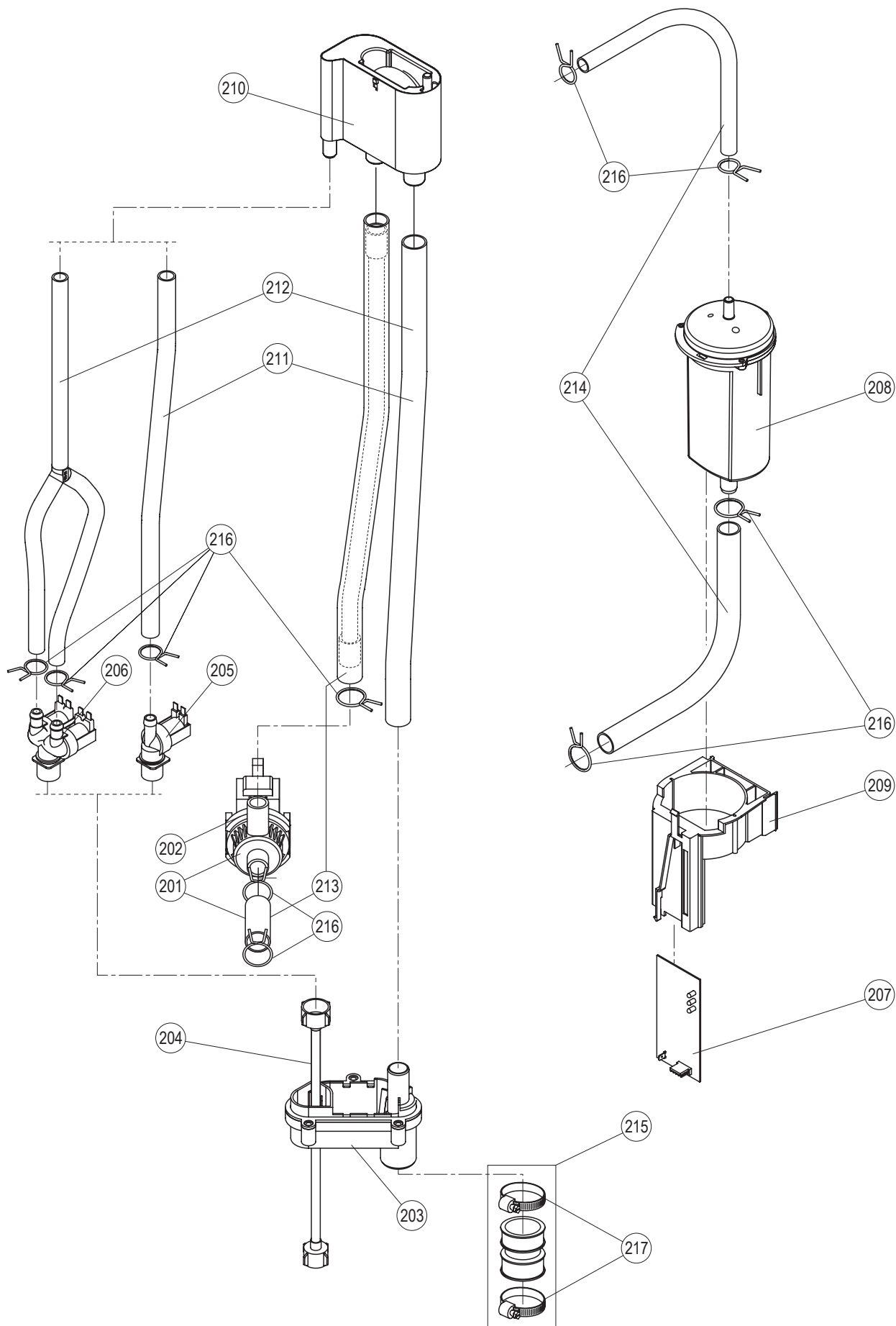

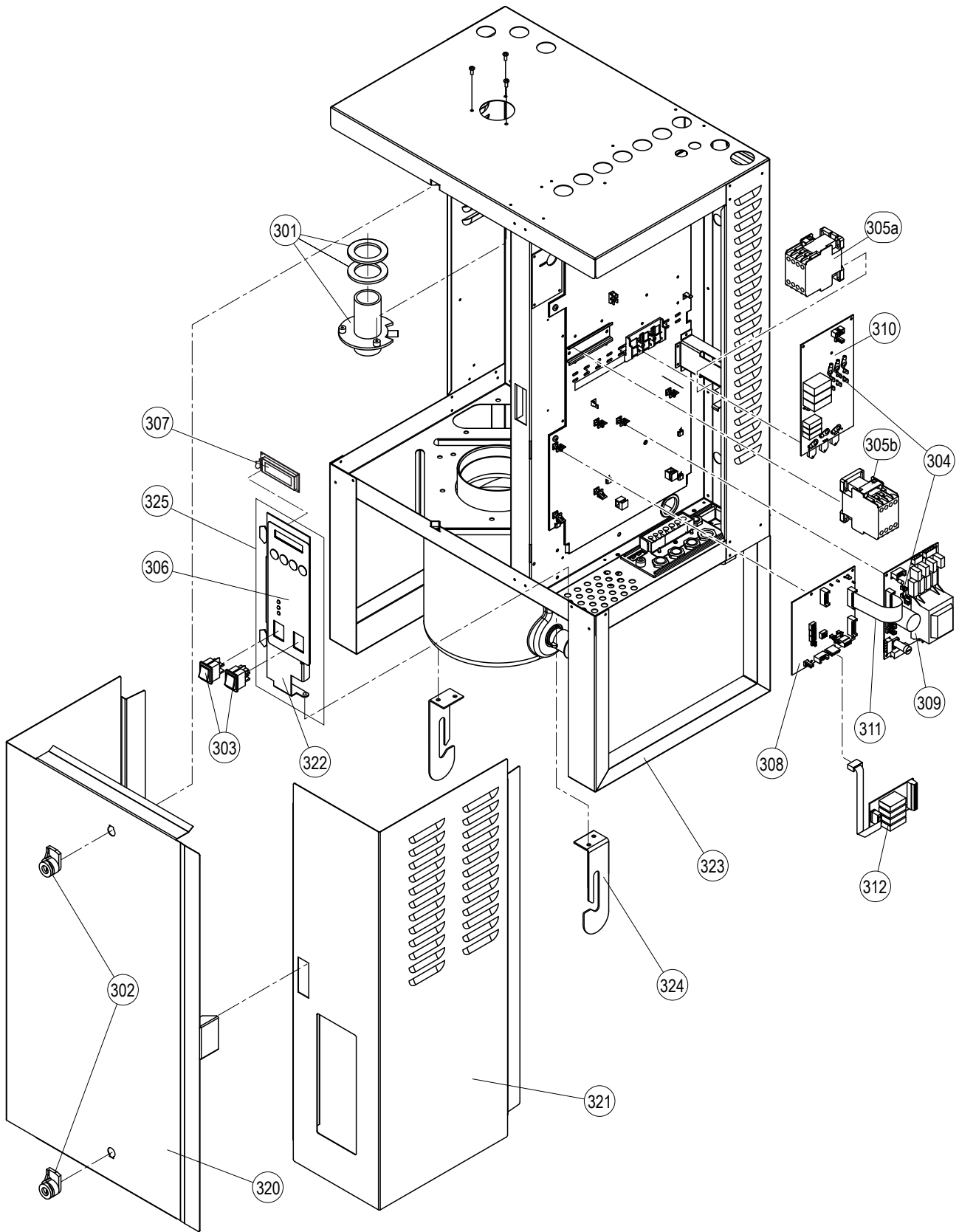

Manufacturer:
 Walter Meier (Climate International) Ltd.
 Talstr. 35-37, P.O. Box, CH-8808 Pfäffikon (Switzerland)
 Phone +41 55 416 61 11, Fax +41 55 416 62 62
www.waltermeier.com, international.climate@waltermeier.com

